



VARIFLEX ACOUSTIC

The sound-insulating operable partition
for perfect interior acoustics

THE RIGHT ACOUSTICS FOR AN ENHANCED IN-ROOM AMBIENCE

Variflex Acoustic absorbs sound and ensures a better in-room ambience.



Sophisticated design of space and function

Flexible room partitions create areas ideal for communication. Spaces for learning, working, presenting, listening or perhaps just quiet enjoyment – they all need to offer good speech intelligibility and listening conditions.

Functional interior acoustics in an elegant design

With its effective acoustic surfaces, Variflex Acoustic complements the Dorma Hüppe Variflex partition system. The elements ensure good sound absorption and improve speech and listening conditions. With their precision perforations and attractive finishes, they also contribute to the visual ambience of an interior.

Variflex Acoustic is available in the following versions for different requirements:

- Variflex Acoustic Classic
- Variflex Acoustic SuperFine
- Variflex Acoustic Light



At parallel events, it is not only the sound insulation between the rooms that is important, but also the appropriate amount of sound absorption within each room unit.

Better hearing and understanding, more quiet and concentration – these contribute to more efficiency and better work results.

VARIFLEX ACOUSTIC CLASSIC

The effective combination of sound insulation and sound absorption

Two perforation patterns with excellent total performance

Two elegant perforation patterns are available for interior acoustic planning. The innovative double-sided acoustic structure, with a low partition thickness of just 120 mm, achieves excellent sound insulation and sound absorption. The sound insulation was tested in the laboratory in combination with the acoustic surfaces. The system also stands out due to its lightness.

Innovative acoustic structure ensures a slim solution with high efficiency

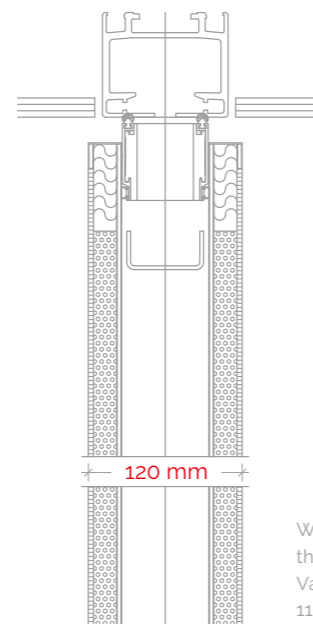

With one-sided acoustics, the partition thickness of Variflex Acoustics Classic is 110 mm.

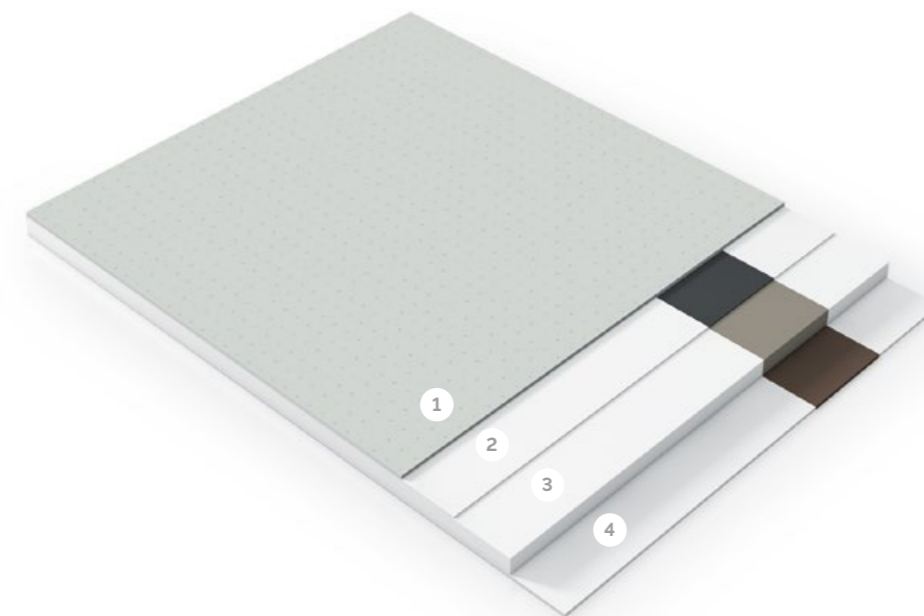

Engineered for excellence:
Overview of the sturdy, sealed panel design:

- 1 Especially perforated composite surface
- 2 Acoustic fleece, black
- 3 Acoustic core, highly absorbent
- 4 Backing board

Variflex Acoustic Classic

Directly mounted	Weight [kg/m ²]	Sound insulation [R _w dB]	Partition thickness in [mm]
2-sided	51	57	120
2-sided	42	53	120

Variflex Acoustic Classic perforation pattern 1 – micro-perforation 1.5 – 6

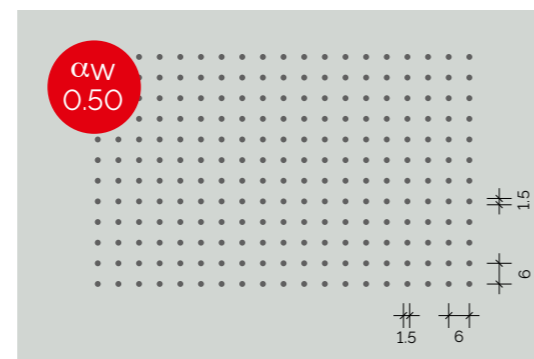
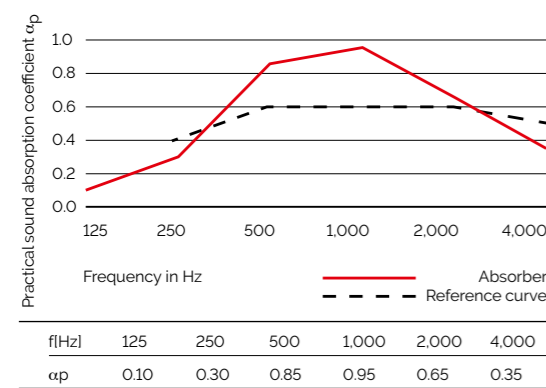

Spacing: 6 mm (horizontal | vertical)
Hole diameter: 1.5 mm | Edge distance: 20 mm

Variflex Acoustic Classic perforation pattern 2 – perforation 3 – 8

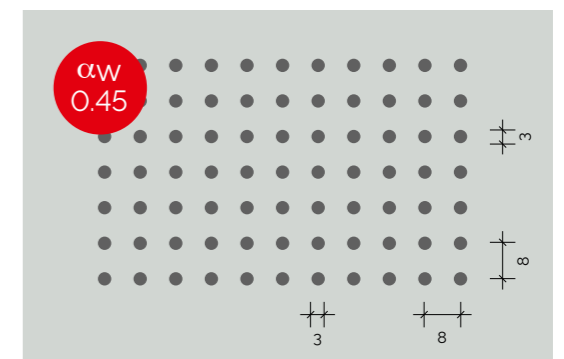
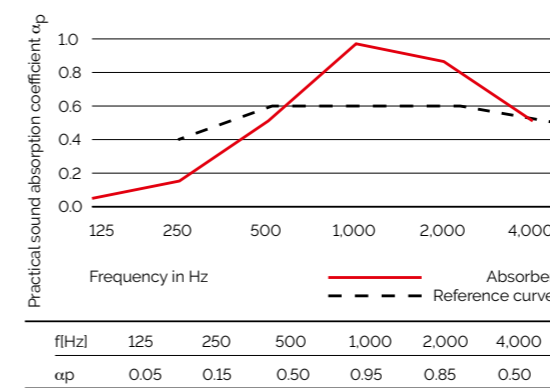

Weighted sound absorption coefficient $\alpha_w = 0.45$
Shape indicator M H

Spacing: 8 mm (horizontal | vertical)
Hole diameter: 3 mm | Edge distance: 20 mm

VARIFLEX ACOUSTIC SUPERFINE

Combines effective sound insulation with the utmost elegance

A room's visual appearance and acoustics shape its character

The elegant acoustic fitting of a Variflex partition not only stands out for its impressive sound insulation and absorption values, which have been tested in combination, but also for its sheer aesthetics. With very high sound absorption and a discreet, barely visible perforation pattern of only 0.5 mm, the super-fine premium version of the acoustic structure increases people's feeling of wellbeing.

Innovative acoustic structure with super-fine premium perforation

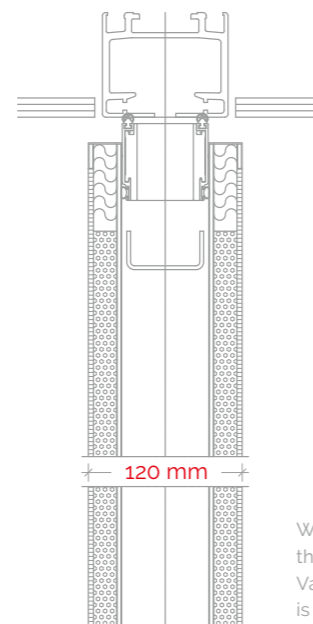

With one-sided acoustics, the partition thickness of Variflex Acoustic SuperFine is 110 mm.

Variflex Acoustic SuperFine

Directly mounted	Weight [kg/m ²]	Sound insulation [R _w dB]	Partition thickness in [mm]
2-sided	51	57	120
2-sided	42	53	120

Variflex Acoustic SuperFine with micro-perforation 0.5 – 1.8

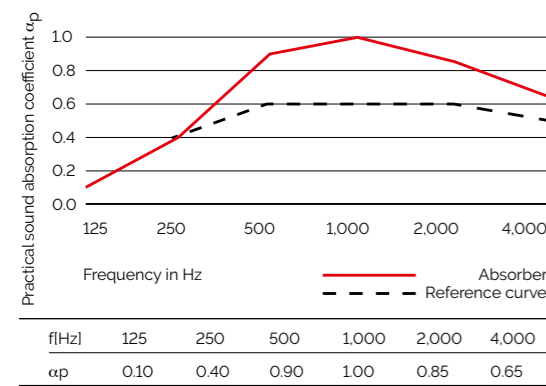

Spacing: 1.8 mm (offset)
Hole diameter: 0.5 mm | Edge distance: 0 mm

Weighted sound absorption coefficient $\alpha_w = 0.70$
Shape indicator M

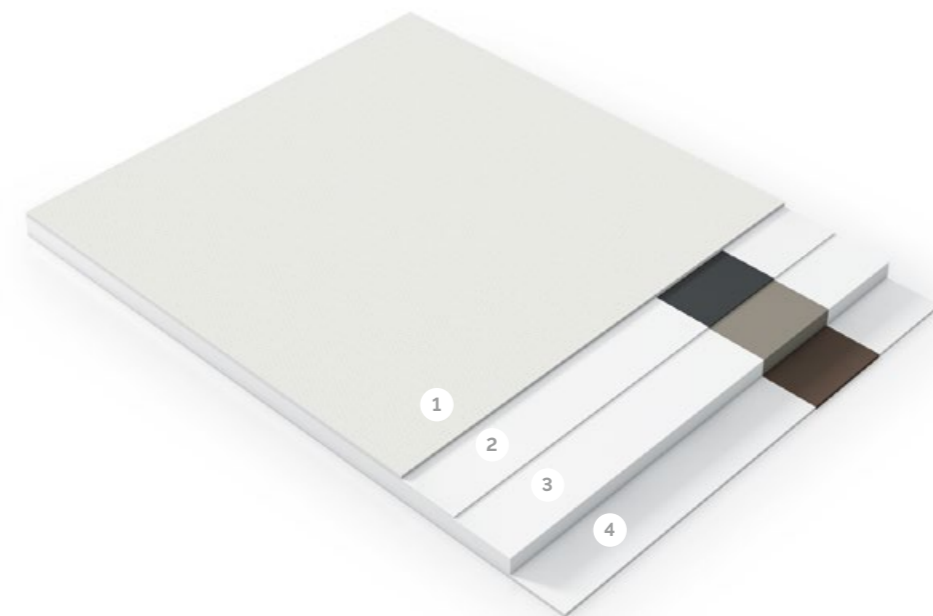

Engineered for excellence:
Overview of the sturdy, sealed panel design:

- 1 Special double perforated composite surface
- 2 Acoustic fleece, black
- 3 Acoustic core, highly absorbent
- 4 Backing board

Effective acoustic surfaces in an elegant perforation design



The microfine perforation ensures balanced room acoustics without compromising appearance



Whether a single or parallel event: it is easier to communicate in an undisturbed atmosphere

VARIFLEX ACOUSTIC LIGHT

Improved room acoustics with constant partition thickness

Save space with constant partition thickness

For rooms with less space in the parking area, this narrow Light version of the Variflex Acoustic is ideal. It improves the room acoustics with a partition thickness of just 100 mm, in which the acoustics are integrated into the surface panel.

With this partition thickness, the combination with Variflex Glass elements is possible without offset.

Double-sided acoustic structure with only 100 mm wall thickness

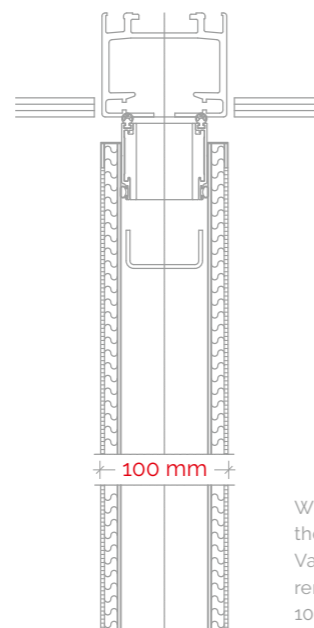

With one-sided acoustics, the partition thickness of Variflex Acoustic Light remains unchanged at 100 mm.

Variflex Acoustic Light

Integrated in surface panel	Weight [kg/m ²]	Sound insulation [R _w dB]	Partition thickness in [mm]
2-sided	57	57	100
2-sided	50	55	100
2-sided	42	54	100

Variflex Acoustic Light with micro-perforation 1.5 – 6

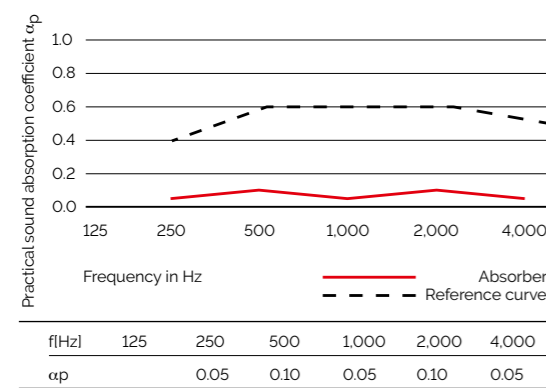

Weighted sound absorption coefficient $\alpha_w = 0.10$

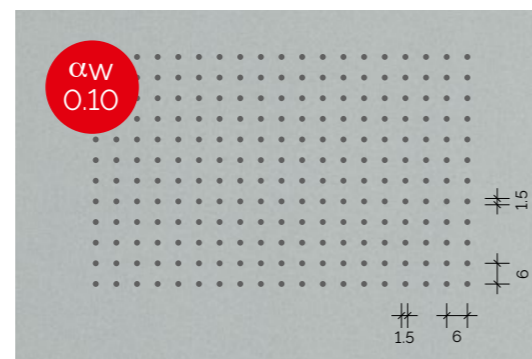

Spacing: 6 mm (horizontal | vertical)
Hole diameter: 15 mm | Edge distance: 20 mm

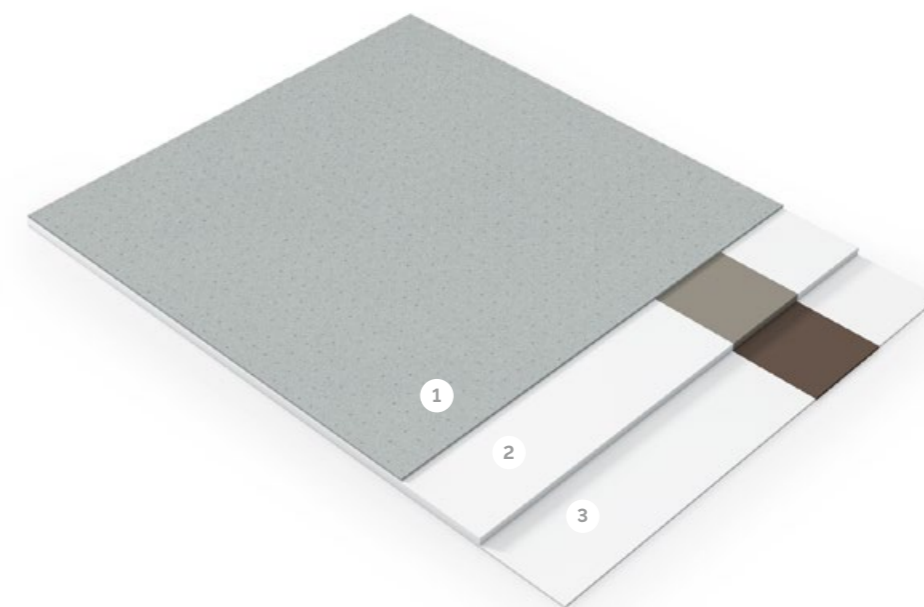

Engineered for excellence:
Overview of the sturdy, sealed panel design:

- 1 Especially perforated composite surface
- 2 Core
- 3 Backing board

Variflex Acoustic Light can be combined with Variflex Glass



More light, more room, more quiet: transparency and sound insulation provide a better in-room ambience.



The joint wall thickness of the partition elements of 100 mm makes it possible to combine them.

PURE DECOR COLLECTION

The Variflex Acoustic collection for individual interior design



Versatile design options with surfaces in four elegant colours

The surfaces of the Pure Decor Collection are specially tailored to the Dorma Hüppe Variflex operable partition system so that the moveable walls can be easily integrated into the interior acoustics planning.

All Variflex Acoustic versions are available with surface decors in four timelessly modern colours. From the discreet white, which lends the room a pleasant sense of generous space and openness, to the bright aluminium decor with its clear, technical radiance – they make Variflex Acoustic a versatile design element in flexible interior planning.

Pure Decor Collection

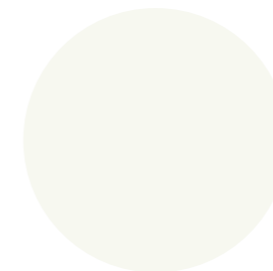

Pure White
Code: A 242 PE
RAL 9010

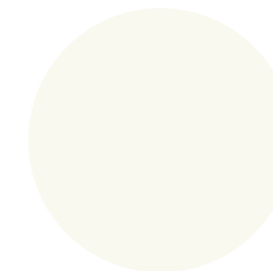

Arctic White
Code: A 222 PE
RAL 9003

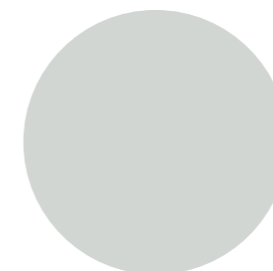

Light Grey
Code: A 402 PE
RAL 7035



White Aluminium
Code: F509 ST2
RAL 9006

Colour deviations from the decor illustrations are due to printing technology. RAL/NCS specifications are approximations to the colour systems and may vary depending on the surface.



 **DORMA**HÜPPE

 **SKYFOLD**

dormakaba Group

DE

**DORMA Hüppe
Raumtrennsysteme GmbH**

Industriestraße 5
26655 Ocholt
GERMANY
P +49 4409 666-0
F +49 4409 666-489
info-hueppe@dormakaba.com
www.dorma-hueppe.com

AT

**DORMA Hüppe
Austria GmbH**

Hollabererstraße 4b
4020 Linz
AUSTRIA
P +43 732 600451
F +43 732 650326
office@dorma-hueppe.at
www.dorma-hueppe.at